

GRAND TOURING[®] SERIES

gto75.2
gto75.4
gto755.6
gto301.1
gto601.1
gto1201.1

car audio
power amplifier
owner's manual



THE OFFICIAL BRAND
OF LIVE MUSIC.



THANK YOU

for purchasing a JBL Grand Touring[®] Series amplifier. In order that we may better serve you should you require warranty service for your new amplifier, please retain your original purchase receipt and return the enclosed warranty registration card.

INSTALLATION

WARNING: Playing loud music in an automobile can hinder your ability to hear traffic and permanently damage your hearing. We recommend listening at low or moderate levels while driving your car. JBL accepts no liability for hearing loss, bodily injury or property damage resulting from the use or misuse of this product.

IMPORTANT: To get the best performance from your JBL Grand Touring® Series amplifiers, we strongly recommend that installation be entrusted to a qualified professional. Although these instructions explain how to install GTO amplifiers in a general sense, they do not show specific installation methods that may be required for your particular vehicle. If you do not have the necessary tools or experience, do not attempt the installation yourself. Instead, please ask your authorized JBL car audio dealer about professional installation.

INSTALLATION WARNINGS AND TIPS

- Always wear protective eyewear when using tools.
- Turn off the audio system and other electrical devices before you start. Disconnect the (–) negative lead from your vehicle’s battery.
- Check clearances on both sides of a planned mounting surface before drilling any holes or installing any screws. Remember that the screws can extend behind the surface.
- At the installation sites, locate and make a note of all fuel lines, hydraulic brake lines, vacuum lines and electrical wiring. Use extreme caution when cutting or drilling in and around these areas.

- Before drilling or cutting holes, use a utility knife to remove unwanted fabric or vinyl to keep material from snagging in a drill bit.
- When routing cables, keep input-signal cables away from power cables and speaker wires.
- When making connections, make certain they are secure and properly insulated.
- If the amplifier’s fuse must be replaced, use only the same type and rating as that of the original. Do not substitute another kind.

CHOOSING A LOCATION AND MOUNTING THE AMPLIFIER

Choose a mounting location in the trunk or cargo area where the amplifier will not be damaged by shifting cargo. Amplifier cooling is essential for proper amplifier operation. If the amplifier is to be installed in an enclosed space, make sure there is sufficient air circulation for the amplifier to cool itself.

When mounting the amplifier under a seat, ensure that it is clear of all moving seat parts and does not affect the seat adjustments. Mount the amplifier so it is not damaged by the feet of backseat passengers. Make sure that the amplifier is mounted securely using nuts and bolts or the supplied mounting screws.

Mount the amplifier so that it remains dry – never mount an amplifier outside the vehicle or in the engine compartment.

POWER CONNECTIONS

The GTO amplifiers are capable of delivering extremely high power levels, and require a heavy-duty and reliable connection to the vehicle’s electrical system in order to perform optimally. See Figure 1 for connection location. Please adhere to the following instructions carefully:

Ground Connection

Connect the amplifier’s Ground (GND) terminal to a solid point on the vehicle’s metal chassis, as close to the amplifier as possible. Refer to the chart below to determine minimum wire-gauge size. Scrape away any paint from this location; use a star-type lock washer to secure the connection.

Power Connection

Connect a wire (see chart at right for appropriate gauge) directly to the vehicle’s positive battery terminal, and install an appropriate fuse holder within 18” of the battery terminal. *Do not install the fuse at this time.* Route the wire to the amplifier’s location, and connect it to the amplifier’s Positive (+12V) terminal. Be sure to use appropriate grommets whenever routing wires through the firewall or other sheet metal. *Failure to adequately protect the positive wire from potential damage may result in a vehicle fire.* When you are done routing and connecting this wire, you may install the fuse at the battery.

Remote Connection

Connect the amplifier’s Remote (REM) terminal to the source unit’s Remote Turn-On lead using a minimum of 18-gauge wire.

NOTE: When using the speaker level inputs, connect the remote (REM) terminal to the source unit. If your source unit does not have a remote turn-on connection, connect the amplifier’s (REM) terminal to the vehicle’s accessory circuit.

Speaker Connections

Refer to the application guides on the pages that follow. Speaker connections should be made using a minimum of 16-gauge wire.

High-Level Input Connections

The GT075.2, GT075.4 and GT075.6 amplifiers are equipped with speaker-level inputs that allow you to add an amplifier to head units that do not have RCA line outputs. The speaker outputs for the source unit should be connected to the amplifier using the supplied connector (square four-wire plug). Remember to check for proper polarity. The GT0301.1, GT0601.1 and GT01201.1 amplifiers are not equipped with high-level inputs.

NOTE: When using the high-level inputs, the AUX outputs can be used to pass a line-level signal to another amplifier.

Wire Gauge Chart

Amplifier Model	Maximum Current Draw	Minimum Wire Gauge
GT075.2	34A	#8 AWG
GT075.4	85A	#8 AWG
GT0755.6	87A	#8 AWG
GT0301.1	40A	#8 AWG
GT0601.1	69A	#6 AWG
GT01201.1	115A	#4 AWG

These recommendations assume 7’ – 10’ wire runs. If your installation differs markedly, you will need to adjust the wire gauge accordingly.

IMPORTANT NOTE: If you are planning to use optional neon tubes, install them before making any electrical connections to the amplifier (refer to “Installing Neon Tubes” on page 6).

Figure 1. Terminal connection end plate.

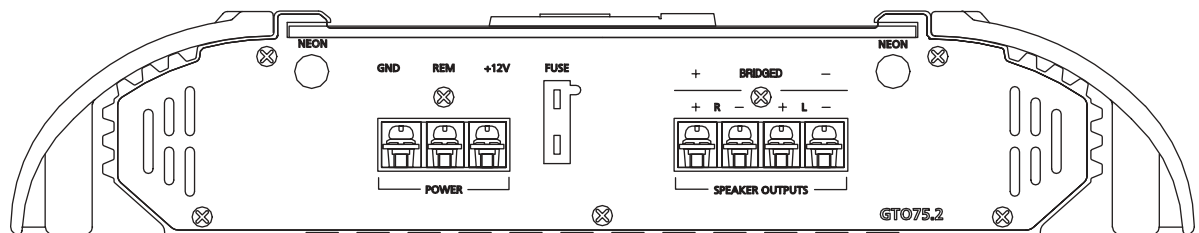

APPLICATIONS - GTO301.1, GTO601.1 AND GTO1201.1

The GTO subwoofer amplifiers are single-channel amplifiers. There are two sets of terminals to make it easy to connect multiple woofers. Either set of (+/-) terminals may be used when connecting woofers.

To the right are two application diagrams to help plan your subwoofer system installation. **Figures 2 and 3** show how to configure the GTO subwoofer amplifiers (models GTO301.1, GTO601.1 and GTO1201.1).

NOTE: For simplicity, Figures 2 and 3 do not show power, remote and input connections.

NOTE: Minimum speaker load is 2 ohms.

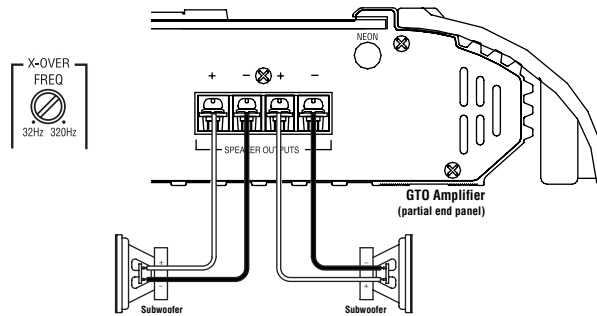

Figure 2. GTO subwoofer amplifier with two woofer connections.

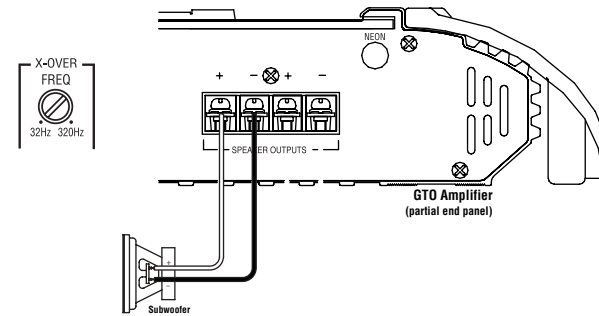

Figure 3. GTO subwoofer amplifier with one woofer connection.

APPLICATIONS - GTO75.2

The JBL GTO75.2 amplifier can be set up for stereo or bridged-mono operation, as shown in **Figures 4 and 5**.

NOTE: For simplicity, Figures 4 and 5 do not show power, remote and input connections.

NOTE: Minimum speaker impedance for stereo operation is 2 ohms. Minimum speaker impedance for bridged operation is 4 ohms.

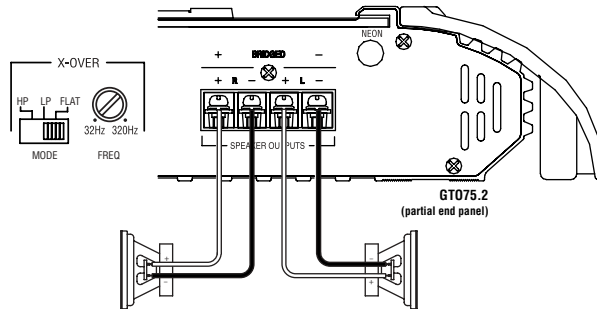

Figure 4. GTO75.2 amplifier set up for stereo operation.

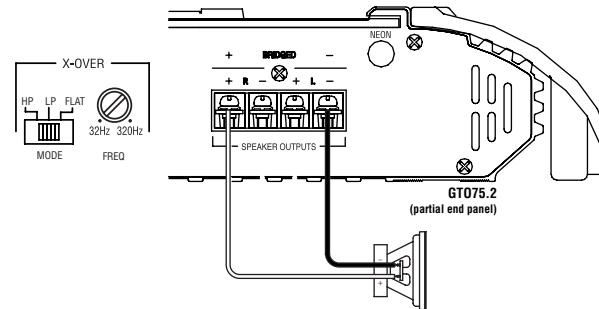

Figure 5. GTO75.2 amplifier set up for bridged-mono operation.

APPLICATIONS - GT075.4

The GT075.4 can be set up for stereo 4-channel, 3-channel or bridged 2-channel operation, as shown in Figures 6 through 8.

NOTE: For simplicity, Figures 6 through 8 do not show power, remote and input connections.

NOTE: Minimum speaker impedance for stereo operation is 2 ohms. Minimum speaker impedance for bridged operation is 4 ohms.

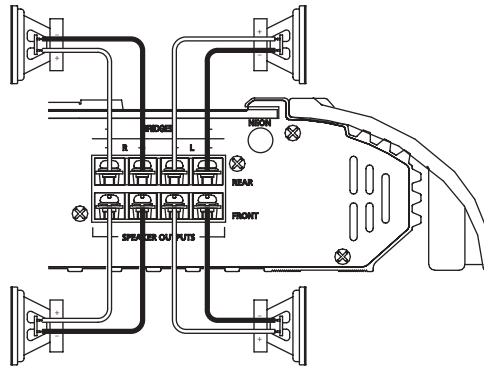

Figure 6. GT075.4 amplifier in 4-channel (stereo) operation to drive front and rear full-range speakers.

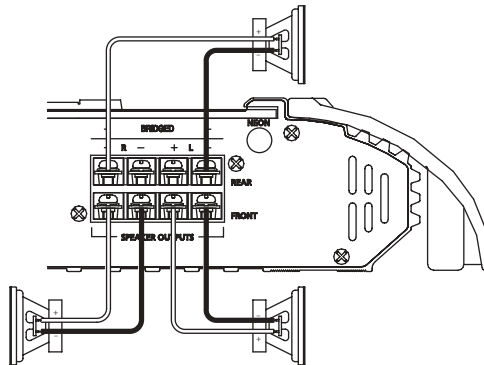
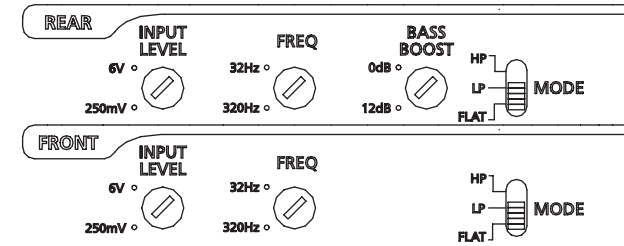

Figure 7. GT075.4 is set up for 3-channel operation to drive a set of full-range speakers and a subwoofer.

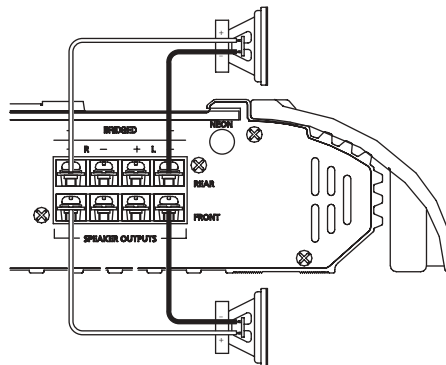
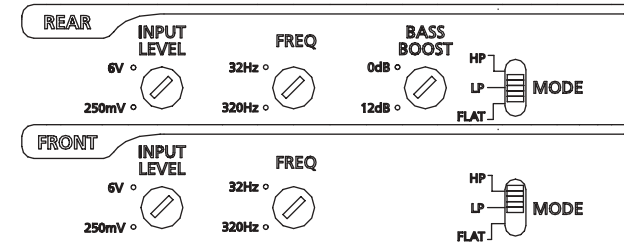
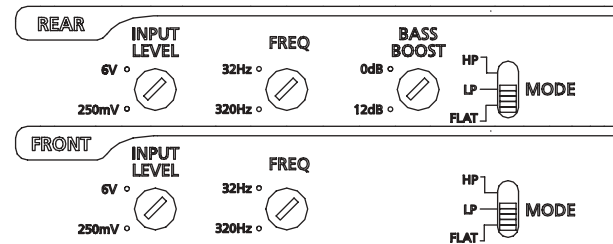

Figure 8. GT075.4 used in bridged 2-channel mode to drive a set of components or subwoofers.



JBL

APPLICATIONS - GT0755.6

The GT0755.6 can be configured for 6-channel, 5-channel or 3-channel operation, as shown in Figures 9 through 11.

INPUT MODE switch:

- Use INT (internal mode) to send a signal from the front and rear inputs to the subwoofer.
- Use EXT (external mode) when sending a dedicated signal to the subwoofer inputs; e.g., if your source unit has a subwoofer output.

NOTE: For simplicity, Figures 9 through 11 do not show power, remote and input connections.

NOTE: Minimum speaker impedance for stereo operation is 2 ohms. Minimum speaker impedance for bridged operation is 4 ohms.

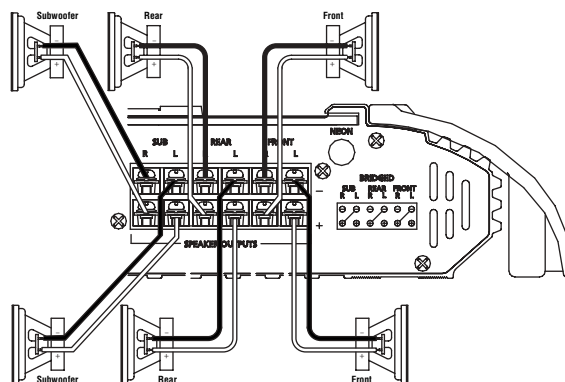

Figure 9. 6-Channel operation: GT0755.6 amplifier driving full-range front and rear speakers and a pair of subwoofers.

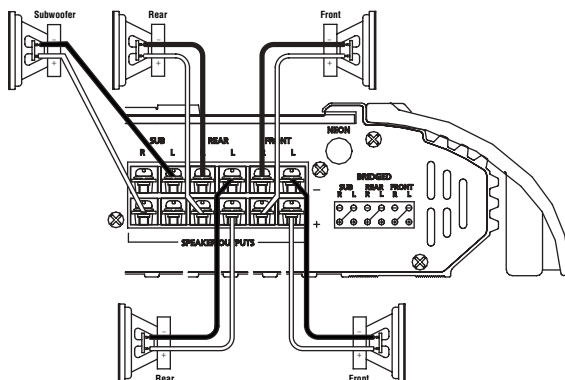
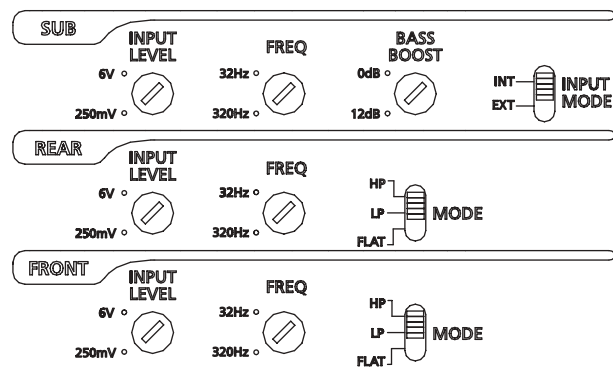

Figure 10. 5-Channel operation: The same as Figure 9, with the subwoofer output bridged to drive a single 4-ohm subwoofer, providing the speaker with more power.

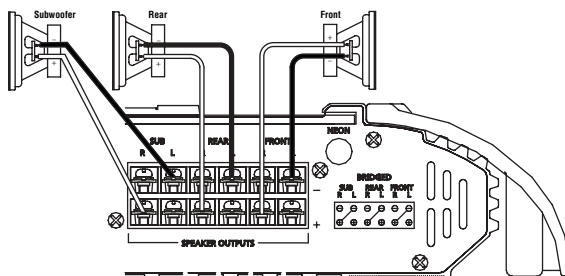
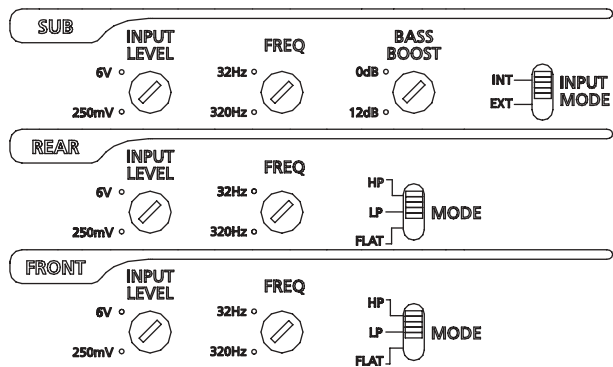
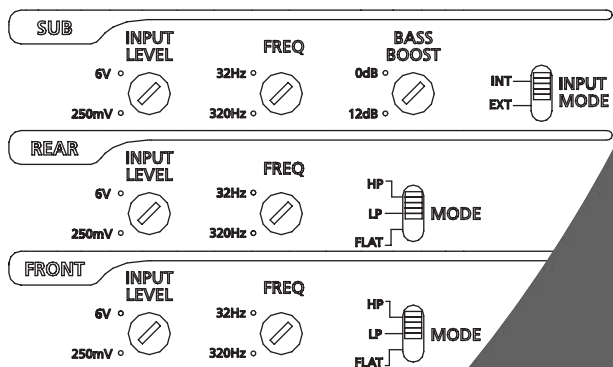

Figure 11. 3-Channel operation: GT0755.6 amplifier configured for 3-channel operation, where all of the channels are bridged for a subwoofer and a pair of component speakers.



JBL

INSTALLATION AND SETUP

SETTING THE CROSSOVER(S)

Determine your system plans and set the crossover mode switch accordingly. If you plan to use the GT075.2 or GT075.4 to drive full-range speakers, set the crossover mode to FLAT and skip to "Setting Input Sensitivity."

Initially set the crossover frequency control midway. While listening to music, adjust the crossover for the least perceived distortion from the speakers, allowing them to reproduce as much bass as possible.

Systems using a separate subwoofer set the crossover mode to HP (high pass) for your full-range speakers. Adjust the crossover frequency to limit bass and provide increased system volume with less distortion.

For subwoofers, choose the highest frequency that removes vocal information from the sound of the subwoofer.

If using the GT075.2 or GT075.4 to drive a subwoofer(s), set the crossover mode to LP (low pass).

NOTE: The GT0301.1, GT0601.1, GT01201.1 and the subwoofer output of the GT0755.6 are low-pass only and do not have a crossover mode switch.

SETTING INPUT SENSITIVITY

1. Initially turn the INPUT LEVEL control(s) to minimum (counter clockwise).
2. Reconnect the (-) negative lead to the vehicle's battery. Apply power to the audio system and play a dynamic music track.
3. On the source unit, increase the volume control to 3/4 volume. Slowly increase the INPUT LEVEL control(s) toward three o'clock until you hear slight distortion in the music. Then reduce the INPUT LEVEL slightly until distortion is no longer heard.

NOTE: After the source unit is on, red LEDs (on the top panel) will light, indicating the amplifier is on. If not, check the wiring, especially the remote connection from the source unit. Also refer to "Troubleshooting" on the next page.

REMOTE LEVEL CONTROL

The GT0755.6 and all three GTO subwoofer amplifiers have inputs for an optional remote level control (RLC). This will allow the amplifier's input level to be adjusted from the listening position. Connect the optional remote level control using the RJ-11 jack on the side of the amplifier. Install the control module in the front of the vehicle within easy reach of the driver. Under the dash or in the center console are both suitable locations.

SETTING THE BASS BOOST

The GT0755.6, GT0301.1, GT0601.1 and GT01201.1 are all equipped with a bass-boost control. This allows you to adjust the bass output of your system at 50Hz up to 12dB and enhance low frequency.

AUX OUTPUT

GTO amplifiers (except GT0755.6) are equipped with full-range outputs that can be used to connect additional amplifiers.

NOTE: When using the high-level inputs, the AUX outputs can be used to pass a line-level signal to another amplifier.

INSTALLING NEON TUBES (OPTIONAL)

1. Using a Phillips screwdriver, remove all screws on the amplifier's output/power end panel and set them aside.
2. Using a 3/32-inch Allen wrench, remove only the screws on the amplifier's (top) clear cover and set them aside.
3. Remove the end panel and slide the cover off. Set both parts aside.
4. Locate the enclosed hardware bag and remove the four clips. Each clip has a square end and a larger round end. Using a round end, press two clips onto each neon tube (e.g., Street Glow AN9 or equivalent), as shown in Figure 13.
5. For each tube, align both clips so the square ends slide onto an exposed extrusion edge, as shown in Figure 9. Do not cover any screw holes. When installed correctly, each neon tube will sit under an extrusion and not be visible when viewed from directly above.
6. Route each neon tube's power cable through its respective NEON hole on the end panel (see Figure 13).
7. Slide the cover back into place and re-install its screws. Then, replace the end panel and reinstall its screws.
8. Finish the installation of the neon tubes as instructed in their owner's manual.

Figure 12. Control end panel.

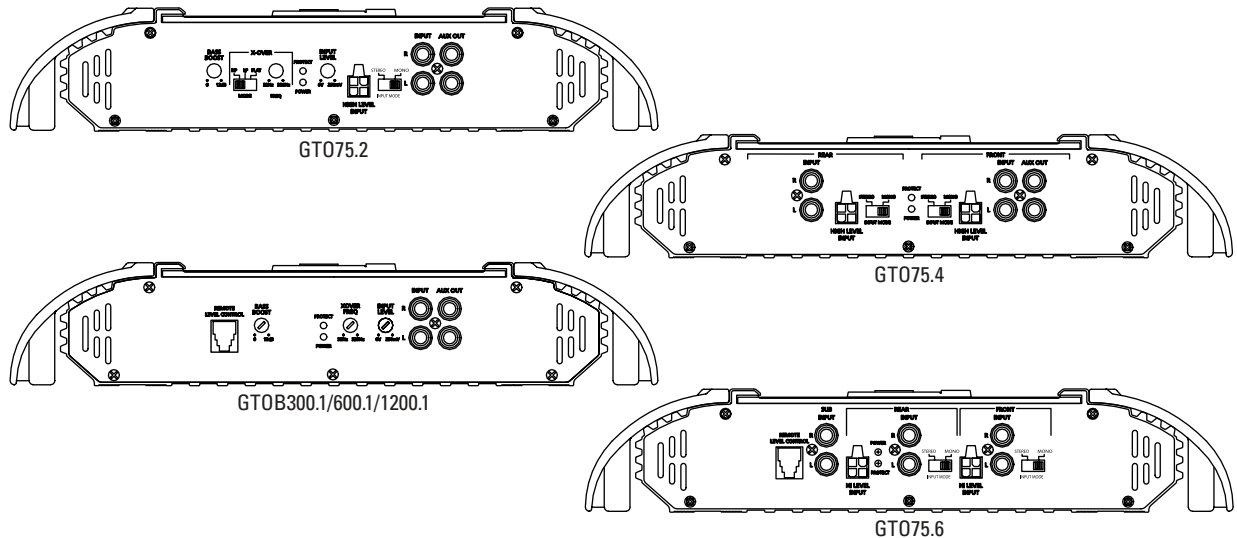

INSTALLATION AND SETUP

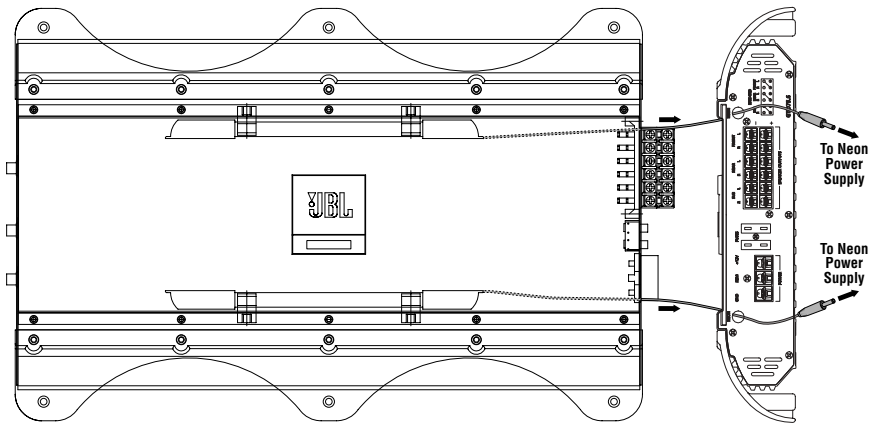

Figure 13. Installing neon tubes in a JBL GTO amplifier.

TROUBLESHOOTING

SYMPTOM	LIKELY CAUSE	SOLUTION	SYMPTOM	LIKELY CAUSE	SOLUTION
No audio (POWER LED is off)	No voltage at BATT+ or REM terminals, or bad or no ground connection	Check voltages at amplifier terminals with VOM	No audio (PROTECT LED is on)	Voltage more than 16V or less than 8.5V on BATT+ connection regulator	Check vehicle charging system for defective voltage
No audio (PROTECT LED flashes every 4 seconds)	DC voltage on amplifier output	Amplifier may need service; see enclosed warranty card for service information	Distorted audio	Input sensitivity is not set properly, or amplifier or source unit is defective	Check INPUT LEVEL setting; or check speaker wires for shorts or grounds
No audio (PROTECT LED is on)	Amplifier is overheated	Make sure amplifier cooling is not blocked at mounting location; verify speaker system impedance is within specified limits (see "Specifications" on the next page)	Distorted audio and PROTECT LED flashes	Short circuit in speaker or wire	Remove speaker leads one at a time to locate shorted speaker or wire, then repair
No audio (PROTECT and POWER LEDs flash)	Voltage less than 9V on BATT+ connection	Check vehicle charging system for defective voltage regulator	Music lacks "punch"	Speakers are not connected properly	Check speaker connections for proper polarity

SPECIFICATIONS

GTO301.1

- 204W RMS x 1 channel at 4 ohms and $\leq 1\%$ THD + N
- Signal-to-noise ratio: 77dBA (reference 1W into 4 ohms)
- 294W RMS x 1 channel at 2 ohms, 14.4V supply and $\leq 1\%$ THD + N
- Dynamic power: 320W at 2 ohms
- Effective damping factor: 6.39 at 4 ohms
- Frequency response: 10Hz – 302Hz (–3dB)
- Maximum input signal: 4.7V
- Maximum sensitivity: 220mV
- Output regulation: .098dB at 4 ohms
- Dimensions (L x W x H): 11-5/8" x 12-5/16" x 2-3/8"

GTO75.2

- 97W RMS x 2 channels at 4 ohms and $\leq 1\%$ THD + N
- Signal-to-noise ratio: 82dBA (reference 1W into 4 ohms)
- 145W RMS x 2 channels at 2 ohms, 14.4V supply and $\leq 1\%$ THD + N
- 290W RMS x 1 channel at 4 ohms, 14.4V supply and $\leq 1\%$ THD + N
- Dynamic power: 190W at 2 ohms
- Effective damping factor: 6.39 at 4 ohms
- Frequency response: 10Hz – 90kHz (–3dB)
- Maximum input signal: 5.5V
- Maximum sensitivity: 230mV
- Output regulation: .098dB at 4 ohms
- Dimensions (L x W x H): 11-5/8" x 12-5/16" x 2-3/8"

GTO601.1

- 424W RMS x 1 channel at 4 ohms and $\leq 1\%$ THD + N
- Signal-to-noise ratio: 72dBA (reference 1W into 4 ohms)
- 580W RMS x 1 channel at 2 ohms, 14.4V supply and $\leq 1\%$ THD + N
- Dynamic power: 778W at 2 ohms
- Effective damping factor: 6.326 at 4 ohms
- Frequency response: 10Hz – 302Hz (–3dB)
- Maximum input signal: 5.3V
- Maximum sensitivity: 210mV
- Output regulation: .21dB at 4 ohms
- Dimensions (L x W x H): 15-1/8" x 12-5/16" x 2-3/8"

GTO75.4

- 104W RMS x 4 channels at 4 ohms and $\leq 1\%$ THD + N
- Signal-to-noise ratio: 80dBA (reference 1W into 4 ohms)
- 142W RMS x 4 channels at 2 ohms, 14.4V supply and $\leq 1\%$ THD + N
- 284W RMS x 2 channels at 4 ohms, 14.4V supply and $\leq 1\%$ THD + N
- Dynamic power: 163W at 2 ohms
- Effective damping factor: 6.384 at 4 ohms
- Frequency response: 10Hz – 83kHz (–3dB)
- Maximum input signal: 5.8V
- Maximum sensitivity: 230mV
- Output regulation: .069dB at 4 ohms
- Dimensions (L x W x H): 15-1/8" x 12-5/16" x 2-3/8"

GTO1201.1

- 787W RMS x 1 channel at 4 ohms and $\leq 1\%$ THD + N
- Signal-to-noise ratio: 70dBA (reference 1W into 4 ohms)
- 1114W RMS x 1 channel at 2 ohms, 14.4V supply and $\leq 1\%$ THD + N
- Dynamic power: 1339W at 2 ohms
- Effective damping factor: 6.348 at 4 ohms
- Frequency response: 10Hz – 302Hz (–3dB)
- Maximum input signal: 6.1V
- Maximum sensitivity: 140mV
- Output regulation: .14dB at 4 ohms
- Dimensions (L x W x H): 18-11/16" x 12-5/16" x 2-3/8"

GTO755.6

- 60W x 4 channels and 107W x 2 channels, at 4 ohms and $\leq 1\%$ THD + N
- Signal-to-noise ratio: 79dBA (reference 1W into 4 ohms)
- 80W x 4 channels, 150W x 2 channels at 2 ohms, 14.4V supply and $\leq 1\%$ THD + N
- 160W x 2 channels, 300W x 1 channel at 4 ohms, 14.4V supply and $\leq 1\%$ THD + N
- Dynamic power: 117W (channels 1, 2, 3, 4); 163W (channels 5, 6) into 2 ohms
- Effective damping factor: 6.392 at 4 ohms
- Frequency response: 10Hz – 47kHz (channels 1, 2, 3, 4); 10Hz – 302Hz (channels 5, 6)
- Maximum input signal: 6V
- Maximum sensitivity: 250mV
- Output regulation: .042dB at 4 ohms
- Dimensions (L x W x H): 18-11/16" x 12-5/16" x 2-3/8"

Declaration of Conformity



We, Harman Consumer International
2, route de Tours
72500 Chateau-du-Loir
France

declare in own responsibility that the product
described in this owner's manual is in compliance
with technical standards:

EN 55013:2001
EN 55020:2002

Emmanuel Millot
Harman Consumer
International
Chateau-du-Loir, France 1/04



JBL Consumer Products
250 Crossways Park Drive, Woodbury, NY 11797 USA
© 2004 Harman International Industries, Incorporated
JBL and Grand Touring are registered trademarks
of Harman International Industries, Incorporated.
Part No. GTOAMPOM1/04
H A Harman International Company

www.jbl.com