

THANK YOU FOR CHOOSING JBL

For more than 60 years, JBL has been involved in every aspect of music and film recording and reproduction, from live performances to the recordings you play in your home, car or office.

We're confident that the JBL® speaker you have chosen will provide every note of enjoy-

ment that you expected – and that when you think about purchasing additional audio equipment for your home, car or office, you will once again choose JBL.

Please take a moment to register your product on our Web site at www.jbl.com. It enables us to keep you

posted on our latest advancements, and helps us to better understand our customers and build products that meet their needs and expectations.

JBL, Inc.

INCLUDED

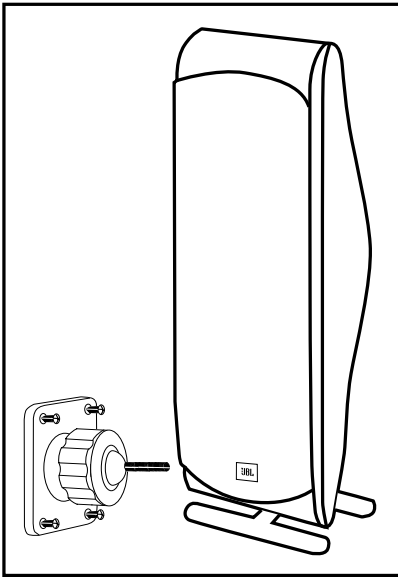

One SCS SAT500, one SCS SAT300 or one SCS SAT200 with wall-mount bracket, shelf stand and floor stand adapter.

One 40' (12m) speaker cable.

In addition, there are two hardware bags included. Hardware Bag A contains the metal tightening bar and screw for the shelf stand. Hardware Bag B contains screws for the floor stand adapter and parts for the wall-mount bracket.

JBL

**SURROUND CINEMA
SPEAKERS**

SCS SAT500 SCS SAT200
SCS SAT300

OWNER'S GUIDE

SPECIFICATIONS

SCS SAT500, SCS SAT300

Maximum Recommended Amplifier Power
100 Watts

Power Handling (Continuous/Peak)
50W/200W

Nominal Impedance 8 Ohms

Sensitivity 88dB @ 1 Watt/1 meter

Frequency Response 100Hz – 20kHz (–6dB)

Tweeter

1/2" (13mm) Titanium-laminate dome,
video-shielded

Midrange

Dual 3" (75mm) drivers, video-shielded

Dimensions (H x W x D) (not including shelf stand)

11-1/2" x 4" x 3-1/2" (292mm x 102mm x 89mm)

Weight 3 lb (1.4kg)

SCS SAT200

Maximum Recommended Amplifier Power
100 Watts

Power Handling (Continuous/Peak)
50W/160W

Nominal Impedance 8 Ohms

Sensitivity 86dB @ 1 Watt/1 meter

Frequency Response 100Hz – 20kHz (–6dB)

Tweeter

1/2" (13mm) Titanium-laminate dome,
video-shielded

Midrange

3" (75mm) Driver, video-shielded

Dimensions (H x W x D) (not including shelf stand)

7-1/4" x 4" x 3-1/2" (184mm x 102mm x 89mm)

Weight 1.75 lb (0.8kg)

Features, specifications and appearance are subject to change without notice.

Dolby is a registered trademark of Dolby Laboratories.

DTS is a registered trademark of DTS, Inc.

Declaration of Conformity



We, Harman Consumer Group, Inc.
2, route de Tours
72500 Château du Loir
France

declare in own responsibility that the products described in this owner's manual are in compliance with technical standards:

EN 61000-6-3:2001

EN 61000-6-1:2001

Laurent Rault
Harman Consumer Group, Inc.
Château du Loir, France 4/07

OWNER'S GUIDE

PRODUCT LINE:

**SURROUND CINEMA
SPEAKERS**

**MODELS: SCS SAT500, SCS SAT300,
SCS SAT200**

DESIGN GOAL: Bring the thrill of live performance and movie sound to the home environment by calling on JBL's professional engineering leadership.

SATELLITE TYPE: Titanium-laminate-dome tweeter, sealed enclosure

PROFESSIONAL REFERENCE: Cinema Loudspeaker Series

**PRO SOUND
COMES HOME™**

Harman Consumer Group, Inc.
250 Crossways Park Drive, Woodbury, NY 11797
8500 Balboa Boulevard, Northridge, CA 91329
516.255.4JBL (4525) (USA only)
www.jbl.com

© 2007 Harman International Industries, Incorporated.
All rights reserved.

JBL is a trademark of Harman International Industries, Incorporated, registered in the United States and/or other countries. Pro Sound Comes Home is a trademark of Harman International Industries, Incorporated.

Part No. 406-000-05723-E

H A Harman International Company

SPEAKER PLACEMENT

FRONT SPEAKERS SURROUND SPEAKERS

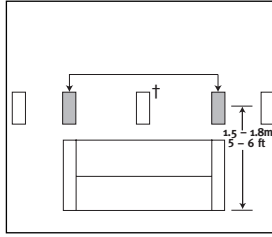
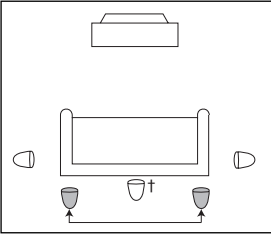

Placement for back speakers.

†Placement for surround back speaker in a 6.1 system.

The SCS SAT500, SCS SAT300 and the SCS SAT200 loudspeakers are designed to be used either singly or in a pair to upgrade a 5.1-channel home theater system to a 6.1- or 7.1-channel system, when connected to a compatible receiver or processor and amplifier.

The rear wall is the required placement for the back surround speakers in a 7.1-channel system. The back surround speaker in a 6.1-channel system should be placed on the wall behind the listening position, facing the center channel speaker.

It is neither necessary nor desirable to tilt the surround speakers to aim them down toward the listening area. They should be aimed straight ahead to produce the proper effect.

MOUNTING OPTIONS

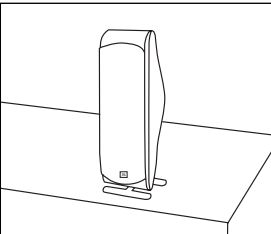

On a shelf.

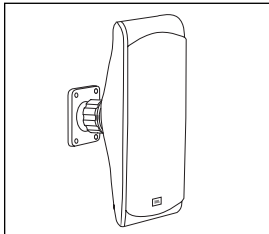

On the wall. A wall bracket is included.

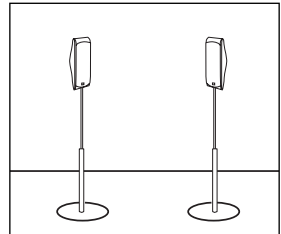

On an optional stand.

ATTACHING THE SHELF STAND TO THE SPEAKER

Prepare the speaker wire as described on Page 5. Thread the two conductors through the two holes in the stand bracket. Make sure to preserve the proper polarity (+ and – connections) by threading the positive conductor through the hole on the left, and the negative

conductor through the hole on the right looking at the stand from the front. Push down on the red speaker terminal and insert the bare end of the positive wire into the hole under the red cap. Release the cap, and tug gently on the wire to make sure that the connection

is snug. Follow the same procedure to connect the negative wire to its terminal. Use the larger screw (Hardware Bag A) in the upper screw hole, and the smaller screw (Hardware Bag A) in the lower screw hole.

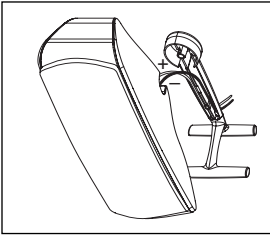

Gently pull the slack out of the wire and screw the shelf stand onto the back of the speaker in two places, as shown.

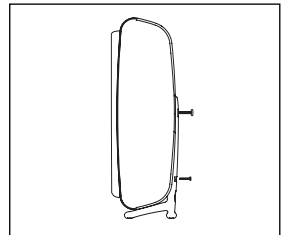

MOUNTING THE SATELLITES ON OPTIONAL FLOOR STANDS

Important Safety Note: *The supplied floor stand adapters facilitate installation with a variety of general-purpose floor stands available from many manufacturers. Since different stands will have different weight capacities and stability characteristics, it is the customer's responsibility to check with the stand manufacturer or dealer to determine whether that specific stand is capable of handling the weight and proportions of these loudspeakers in a safe and stable manner. JBL disclaims any liability for the selection of suitable floor stands and/or correct compatibility between the selected stand and these satellite loudspeakers.*

The floor stand adapters are compatible with floor stands equipped with a 1/4"-20 threaded insert.

Prepare the speaker wire as described on Page 5. Thread the two conductors through the two holes in the floor stand adapter. Make sure to preserve the proper polarity (+ and – connections) by threading the positive conductor through the hole on the left, and the negative conductor through the hole on the right (looking at the front of the adapter). Push down on the red speaker terminal and insert the bare end of the positive wire into the hole under the red cap. Release the cap, and tug gently on the wire to make sure that the connection is snug. Follow the same

procedure to connect the negative wire to its terminal.

Gently pull the slack out of the wire and screw the adapter onto the back of the speaker in two places, as shown.

The floor stand adapter screws may be found in Hardware Bag B. Use the larger screw in the upper screw hole, and the smaller screw in the lower screw hole.

Screw the floor stand adapter into the floor stand's threaded insert until the speaker is firmly attached to the stand. Back off slightly from the fully tightened position until the speaker is oriented as desired, then rotate the thumbwheel at the bottom of the floor stand adapter to secure the speaker to the stand.



WALL-MOUNTING

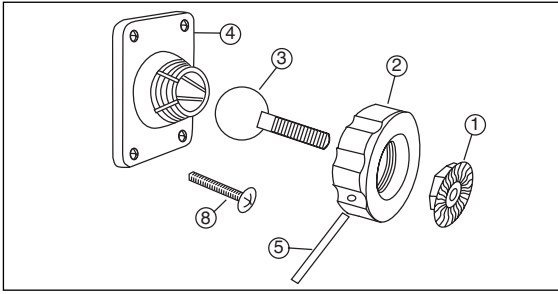

Important Safety Note: *The customer is solely responsible for proper selection of mounting hardware not included with the speaker, and for proper assembly and installation of the wall-mount bracket, including but not limited to the selection of appropriate weight-bearing supports and proper use of the bracket. JBL disclaims any liability for the selection of mounting hardware and/or bracket installation. Be sure to follow these bracket assembly and installation instructions carefully. If you have any questions or doubts about your ability to correctly wall-mount the speakers, consult your authorized JBL dealer or custom installer.*

Step 1: Unscrew and remove the large **Molded Nut 2**. If necessary, use the supplied **Metal Bar 5** as a lever by inserting it into one of the holes in the outer edge of the **Molded Nut 2**.

Step 2: Firmly grasp the **Ball and Shaft 3** and pull it straight out of the **Attachment Plate 4**. Avoid leaning it to the side for leverage, as this may break off a tab.

Step 3: Slide the **Molded Nut 2** onto the **Ball and Shaft 3** with the threaded opening facing the ball. Thread the **Metal Nut 1** all the way onto the **Ball and Shaft 3**,

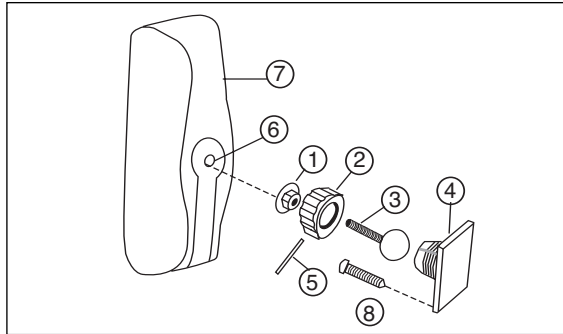

with the star washer side away from the ball. Refer to the exploded drawing for the proper orientation of these parts.

Step 4: Screw the **Ball and Shaft 3** into the **Threaded Insert 6** on the back of the **Satellite Speaker 7** until it is fully seated in the **Threaded Insert 6**, but *do not* tighten, as you might dislodge the **Threaded Insert 6**. Such damage would not be covered under the warranty.

Step 5: Tighten the **Metal Nut 1** with the star washer side between the **Metal Nut 1**

and the back of the **Satellite Speaker 7**, using large needle-nose pliers until it is firmly seated against the back of the **Satellite Speaker 7** and has locked the **Ball and Shaft 3** and the **Satellite Speaker 7** together.

NOTE: Once the **Metal Nut 1** is fully tightened, it may embed some marks on the back of the **Satellite Speaker 7**. However, these marks will be covered by the **Metal Nut 1**.

Step 6: Mount the **Attachment Plate 4** into a wood stud on the wall, using four

#10 panhead wood screws **8** at least one inch long (not supplied). Make sure that all four screws are driven into the stud and not into drywall. *If the bracket needs to be mounted in drywall, the customer is responsible for selecting and using appropriate wall anchors and screws.*

IMPORTANT NOTE: The **Metal Nut 1** must be fully tightened against the **Satellite Speaker 7** as described in Step 5 before beginning Step 7, in order to avoid damage to the **Threaded Insert 6**.

Such damage would not be covered under the warranty.

Step 7: Holding the **Satellite Speaker 7** with both hands, reinsert the ball portion of the **Ball and Shaft 4** into the **Attachment Plate 4**.

Step 8: Hand-tighten the **Molded Nut 2** while positioning the speaker for the desired orientation. If the **Molded Nut 2** is difficult to tighten by hand, insert the **Metal Bar 5** into one of the holes in the outer edge of the **Molded Nut 2** and use the bar as a lever. Be careful

not to cross-thread. The swiveling ball enables you to aim the speaker to one side or the other, or to tilt it up or down. Although stereo imaging may be improved by aiming the front speakers toward the listening position, especially for music selections, the surround speakers are intended to provide a diffuse, ambient sound that is best achieved by aiming the speakers straight out from the wall. Aiming the surround speakers toward the listening position may

ruin the intended effect by calling too much attention to the information in those channels.

Step 9: Once the speaker's orientation has been finalized, insert the **Metal Bar 5** into one of the holes in the outer edge of the **Molded Nut 2** and tighten the **Molded Nut 2** securely. Keep the **Metal Bar 5** in a safe place, in the event that you decide to adjust the speaker's orientation in the future.

SPEAKER CONNECTIONS

CONNECTION TIPS

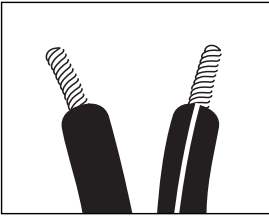

Separate and strip the ends of the speaker wire as shown. The wires supplied with the system may already be stripped and tinned for easy insertion into the speaker terminals. You may need to separate the two conductors further in order to thread them through the shelf stand or floor stand adapter. Speakers and electronics terminals have corresponding (+) and (-) terminals. Most manufacturers of speakers and electronics, including JBL, use red to

denote the (+) terminal and black to denote the (-) terminal.

The (+) lead of the speaker wire is noted with a stripe. It is important to connect both speakers identically: (+) on the loudspeaker to (+) on the amplifier and (-) on the loudspeaker to (-) on the amplifier. Wiring "out of phase" results in thin sound, weak bass and a poor stereo image.

With the advent of multi-channel surround sound systems, connecting all of the speakers in your system with the correct polarity remains equally important in order to preserve the proper ambience and directionality of the program material.

To connect the supplied speaker wires to the satellite

and center speaker terminals, press the red or black plastic cap for the desired terminal, insert the bare end of the wire into the hole below the cap and release the cap. Gently tug on the wire to make sure that it is fully inserted.

SYSTEM CONNECTION

Connect each speaker to the corresponding speaker terminals on your receiver or amplifier.

If you are using a subwoofer, follow the directions in that owner's guide to connect and configure it.

Configure your receiver or processor to reflect the correct number of speakers in your system. If you have added one SCS SAT500/300/200 speaker to a 5.1-channel system, reconfigure it as a 6.1 system. If you have added two SCS SAT500/300/200 speakers to a 5.1-channel system, reconfigure it as a 7.1 system.

The SCS SAT500/300/200 should be set to "Small." If your receiver allows you to set the crossover frequency between the subwoofer and the speakers, select 100Hz or the setting that is the closest frequency below it.

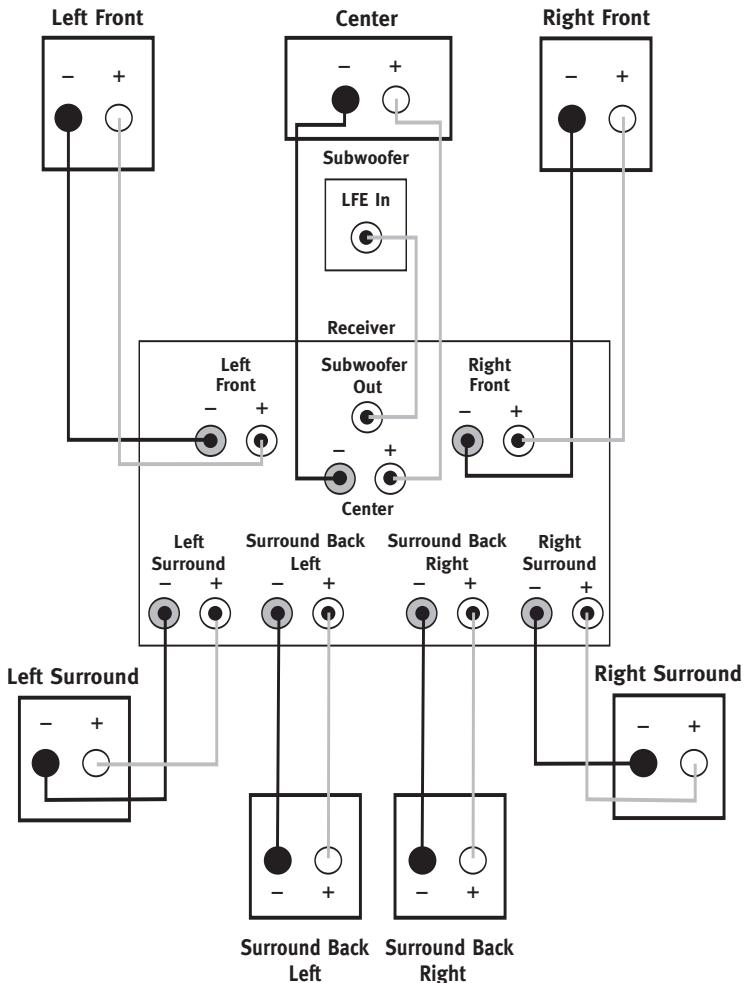

TROUBLESHOOTING

If there is no sound from any of the speakers:

- Check that receiver/amplifier is on and a source is playing.
- Check all wires and connections between receiver/amplifier and speakers. Make sure all wires are connected. Make sure none of the speaker wires are frayed, cut or punctured, or touching each other.
- Review proper operation of your receiver/amplifier.

If there is no sound coming from one speaker:

- Check the "Balance" control on your receiver/amplifier.
- Check all wires and connections between receiver/amplifier and speakers. Make sure all wires are connected. Make sure none of the speaker wires are frayed, cut or punctured, or touching each other.
- In Dolby® Digital or DTS® modes, make sure that the receiver/processor is configured so that the speaker in question is enabled.
- Turn off all electronics and switch the speaker in question with one of the other speakers that is working correctly. Turn everything back on, and determine whether the problem has followed the speaker, or has remained in the same channel. If the problem is in the same channel, the source of the problem is most likely with your receiver or amplifier, and you should consult the owner's manual for that product for further information. If the problem has

followed the speaker, consult your dealer for further assistance or, if that is not possible, visit www.jbl.com.

If the system plays at low volumes but shuts off as volume is increased:

- Check all wires and connections between receiver/amplifier and speakers. Make sure all wires are connected. Make sure none of the speaker wires are frayed, cut or punctured, or touching each other.
- If more than one pair of main speakers is being used, check the minimum impedance requirements of your receiver/amplifier.

If there is low (or no) bass output:

- Make sure the connections to the left and right "Speaker Inputs" have the correct polarity (+ and -).
- If your system includes a subwoofer, check its operation and the configuration of your receiver or processor. If your system has no subwoofer, consider adding a powered subwoofer.

If there is no sound from the surround speakers:

- Check all wires and connections between receiver/amplifier and speakers. Make sure all wires are connected. Make sure none of the speaker wires are frayed, cut or punctured, or touching each other.
- Review proper operation of your receiver/amplifier and its surround sound features.

- Make sure the movie or TV show you are watching is recorded in a surround sound mode. If it is not, check to see whether your receiver/amplifier has other surround modes you may use.
- In Dolby Digital or DTS modes, make sure your receiver/processor is configured so that the surround speakers are enabled. When five satellites are in use, remember to configure your receiver or processor for 6.1-channel operation, and when six satellites are in use, configure your receiver or processor for 7.1-channel operation.
- Review the operation of your DVD player and the jacket of your DVD to make sure that the DVD features the desired Dolby Digital or DTS mode, and that you have properly selected that mode using both the DVD player's menu and the DVD disc's menu.